

## MODEL 5145 ACHILLES LOAD CELL

### Applications:

The ACHILLES Load Cell (Model# 5145) is a one-channel force (Fz) measuring device. It is designed to measure the force at the Achilles Tendon of the THOR-LX lower leg assembly.

### Standard Ordering Configuration: 5145J

For optional configurations, see load cell ordering guide or consult factory.

### Specifications:

Channel	Capacity		Bridge Resistance (nom)	Output Sensitivity (nom)
	Metric	English		
Fz	4.5 KN	1000 lbf	360 ohms	1.0 mV/V

Non-linearity ..... less than 1% of full scale  
 Hysteresis..... less than 1% of full scale  
 Excitation..... 10 VDC nom. 15 VDC max.  
 Assembly Mass (without cable, with mounting screws)..... (0.06 lb) 25 g

### Wiring:

Fz Channel	
Red	+Exc
Green	+Sig
Black	-Exc
White	-Sig



## MODEL 5145 ACHILLES LOAD CELL

### NOTES

1. Use Denton Model 5165 calibration fixture. (Ref. Calibration Fixture drawing 5145-C)
2. This load cell is wired for SAE J211 Right Hand Rule sign convention indicated by the suffix "J" on the model tag on the load cell.
3. If the model tag on the load cell includes a "G" suffix, the shield of the cable is grounded to the body of the part.
4. If the model tag on the load cell includes an "I" suffix, there is an ID module in the body of the load cell. The number following the "I" indicates the type of ID module.
5. The standard cable length for this load cell is 9.1 meters (30'). If the cable is cut shorter, the calibration will change. Upon request, the load cell can be made and calibrated with a custom cable length.

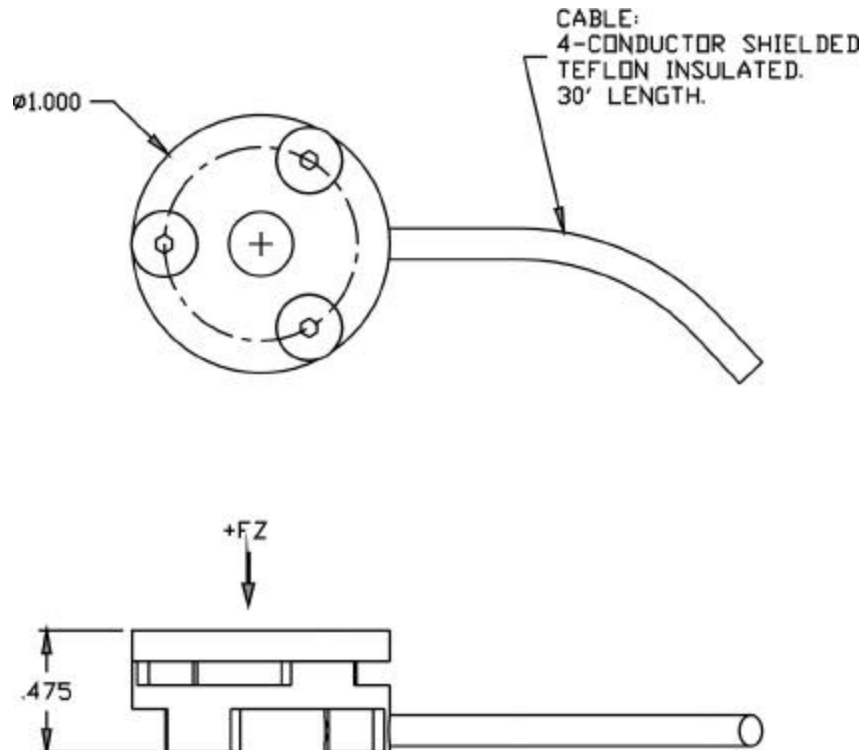

### *Creating the Standard in Safety Measurement Since 1974*

Robert A. Denton, Inc. maintains a high level of control over the manufacture of its products to ensure quality, accuracy and reliability. Continued improvement necessitates that we reserve the right to modify these specifications without notice.

Robert A. Denton, Inc., 2967 Waterview Drive, Rochester Hills, Michigan 48309  
Tel: (248) 852-5100 • Fax: (248) 852-6060 • email: info@radenton.com  
Copyright © R. A. Denton, Inc., 7 August 2001

Issue Date: 06AUG01